

Personal possessions, household objects, and indicating position

Level: ESOL Step 2 Award

Focus: Possessions at home

Time: 70 minutes

Aims:

- ▶ To practise understanding and using lexis to indicate position
- ▶ To practise understanding and using lexis for possessions and household objects, rooms and furniture

Resources:

- ▶ Pictures of, or actual personal possessions
- ▶ A copy of Worksheets 1, 2, and 3 for each student

Preparation

1. Assemble common personal possessions: phone, keys, glasses, wallet, notebook, pen, bag, hat, scarf. Choose one (that typically you are always mislaying eg phone or bag) and which does not need a plural verb (viz NOT glasses, keys) and take photos of it in various locations in the home.
2. The object can be: in/on/under/between, and next to locations such as: computers, tables, chairs, lamps, sofas, pianos, mirrors, cupboards etc. You could include it in an unlikely place to provide amusement (eg in a pet's bed or in a shoe.) See examples on the provided materials.
3. Print copies of Worksheets 1, 2, and 3 for each student.

In class

Introducing the lexis for places in the home and assessing use of prepositions of place (10 minutes)

1. Personalise your chosen possession. Encourage questions about it (could be a present or a recent purchase.)
2. Show them each picture of the possession and ask where it is. Try to elicit the target vocabulary: the room or a piece of furniture for example, and the preposition of place, eg 'on', 'next to'. If the students don't know this language, just model it for them and point to the picture, eg 'It's on the table!', then move on to the next picture.

Personal possessions, household objects and indicating position

ESOL Step 2 Award

Where is it? (10 minutes)

1. If your class is larger than six, divide the class into groups of about three or four and give each group a set of flashcards with either your photos or the ones provided on Worksheet 1. If using worksheet 1 explain that you have a pet, a cat and it hides in many places.
2. Give them a few minutes to match the sentence with the corresponding photograph. When they've matched them, encourage them to practise saying the sentences.
3. Monitor and support them with pronunciation when needed. In feedback, elicit the correct answers from the students, and confirm them by matching a set of flashcards on the board.

Other household objects (10 minutes)

1. Give the students Worksheet 3 and get them to match the images of household objects to the corresponding word. Encourage them to compare their answers and try to say the words together. Monitor and listen out for good examples so you can nominate those students in feedback.
2. Check students understand all the words, model pronunciation and get the students to repeat the words several times.

Where are they? (10 minutes)

1. Give the students Worksheet 3 and get them to complete the gaps with the preposition of place using the picture to decide. Give them about 4 minutes to work alone, then get them to compare answers in pairs.
2. Monitor and listen out for any difficulties your students are having with any of the language in the task. Help these students straight away, but remember to review the issue in group feedback too.

Practise: role play(10 minutes)

1. Ask students what objects they commonly lose in the home. (Typically - keys, phone, wallet, hat, scarf, gloves, glasses). You could have a picture of an elderly person who might be your relative.
2. Arrange the classroom and designate for example a couple of chairs together as "sofa". You can use shelf table window door, computer.
3. Hold up an object and practice "Oh dear! Where's myhat?" Or "Oh dear. Where are my keys?" Draw attention to the change of the verb from singular to plural.
4. Student 1 chooses an object, gives it to a fellow student 2 and then goes outside the door. Student 2 hides the object. Student 1 comes in and asks another student "Oh dear! Where is/ are my"
5. The third student responds.
6. Divide the class into small groups. Give each group a set of flashcards with either your photos or the ones provided on Worksheet 1 (they don't need the cards with the words/sentences on them).

Personal possessions, household objects and indicating position

ESOL Step 2 Award

7. Get the students to work through each photo, deciding together how best to say where it is, eg 'The keys are on the bed.'

Feedback

1. Write down five or six things on the board you noticed when monitoring. Then give the students a few minutes to discuss in pairs what they think is wrong with the sentences. If a word has been mispronounced, highlight this in a different colour to make sure the students think about the way to say the words correctly with their partner.
2. As you monitor, notice who is managing to correct the sentences, or pronounce the words correctly to nominate in feedback. Finally, elicit correct answers from the group and write the correct versions on the board, modelling the correct pronunciation, and ask the students to repeat the words a few times.

Personal possessions, household objects and indicating position

ESOL Step 2 Award

Worksheet 1 – Where is it?

Match the picture to the sentence.

- A** It's on the bed.
- B** It's next to the door
- C** It's under the table.
- D** It's on the sofa.
- E** It's in my shoe!

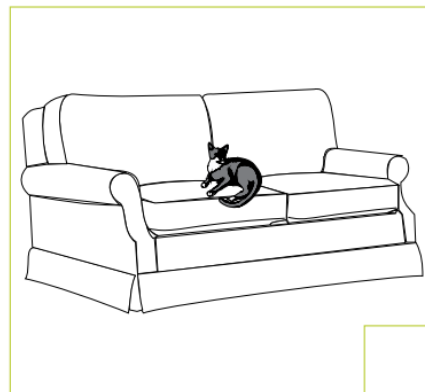
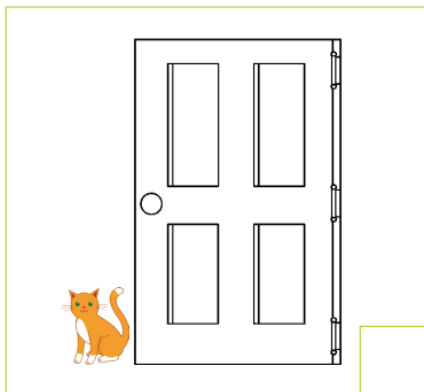
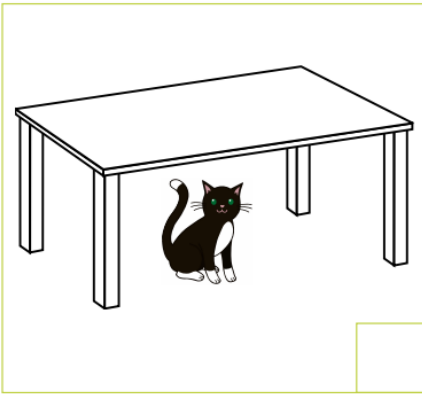

Personal possessions, household objects and indicating position

ESOL Step 2 Award

Worksheet 2 – What object is it?

Match the pictures to the word.

- | | |
|----------|----------|
| A | table |
| B | chair |
| C | sofa |
| D | TV |
| E | bed |
| F | computer |

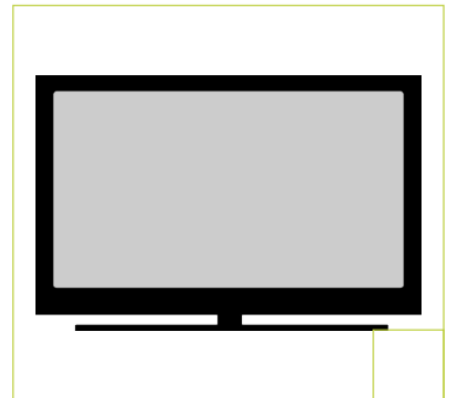
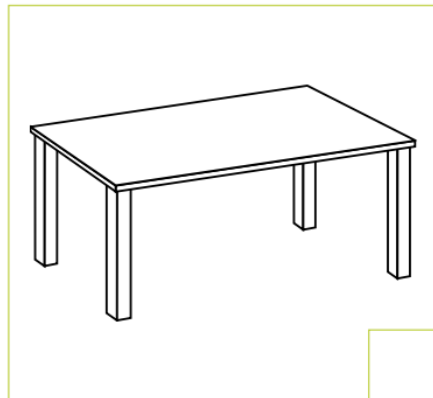
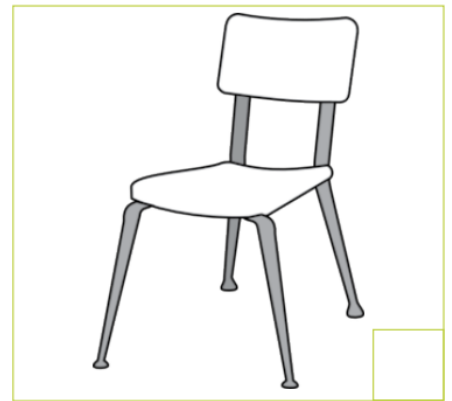
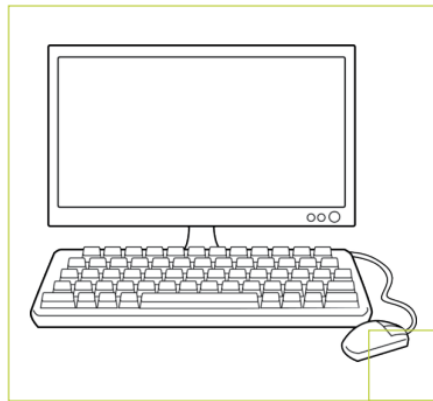
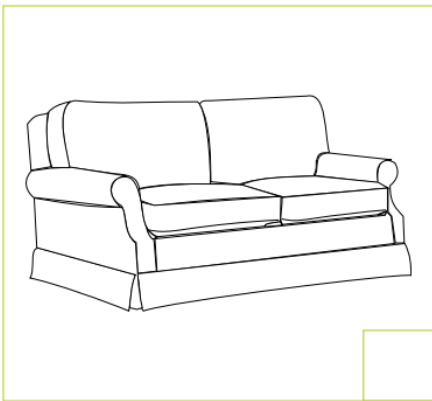

Personal possessions, household objects and indicating position

ESOL Step 2 Award

Worksheet 3 – Where is it?

Complete the sentence with the correct preposition: *on, in, under, between* or *next to*.



1. She's _____ my bed!

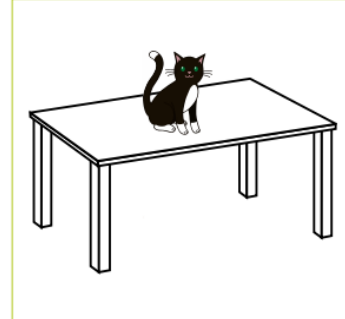

2. She's _____ the table.

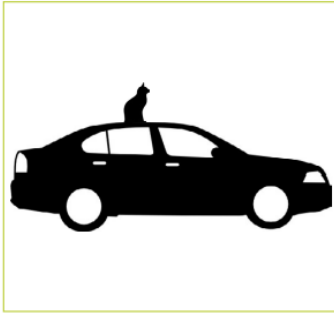

3. My cat is _____ the car.

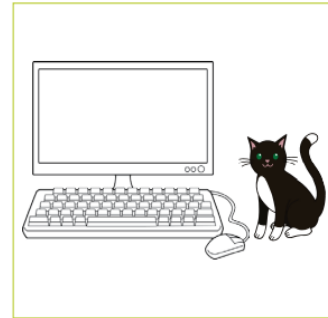

4. She's _____ the computer.

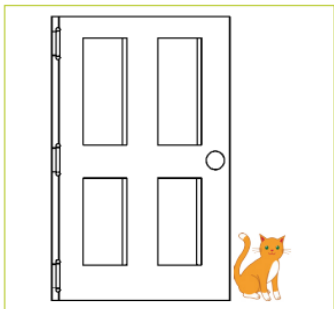

5. She's _____ the door.



6. She's _____ the cupboard.

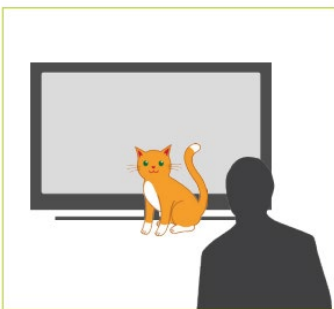

7. She's _____ the TV and me!